



Astrimar
Reliability by Design



Delivering engineered solutions,
reliability and integrity





Engineered Solutions

Technology Qualification

Asset Integrity

CONTENTS

About us

Our vision and values	3
Our track record	4
Industry sectors	6

Engineered Solutions

Innovative solutions	7
Engineering analysis	8
Case studies	9

Asset Integrity

Asset integrity management	11
Decommissioning	12
Data analysis	13

Technology Qualification

Technology qualification support	14
--	----

Specialist Software

RAPAT	15
pRIOritiAIM	16
STEMflow	16

Reliability Engineering

Reliability analysis tools and techniques	17
---	----

OUR VISION AND VALUES

Astrimar's goal is to **add value** to our client's business by supporting the delivery of **highly reliable** systems and **engineered solutions**, providing design, analysis, assurance, and verification.

Industries face ever-growing challenges to enable more efficient harvesting of the world's natural resources supporting transition to a net zero economy. Increasingly complex and advanced technology is being utilised, often in new or demanding environments, introducing technical risks which need to be effectively managed.

Our specialist engineering and consultancy services are targeted at helping clients manage risks to achieve maximum uptime and operational efficiency whilst maintaining the highest levels of integrity. This is vital to long term economic success and prevention of harm to the environment.

We don't force fit a pre-conceived idea or fixed approach but listen to our client's needs. Our reputation is built on providing flexible, tailored solutions adjusted to the client business model, operational schedule, technical needs and capabilities.

Sustainability is at the core of everything we do. The reliability-centred solutions we provide to our clients inherently reduce emissions and waste. We continually seek to find ways to reduce our carbon footprint in both our business management decisions and our individual lives, with offices intentionally located to support this.

We are a specialised engineering consultancy with reliability at the heart of everything we do"

"Our passion is to help clients understand and prevent failures by incorporating reliability into everyday business"

Caroline Roberts Haritonov
Managing Director, Astrimar

OUR TRACK RECORD

Our **internationally recognised** team has decades of experience in providing **highly effective solutions** and **best practice** to deliver reliability-centred design, technology qualification and integrity assurance.

Based near Aberdeen and London, Astrimar has been influential in the development and implementation of reliability, integrity and technology qualification best practice within the subsea and wider oil and gas industry, driving a step change in reliability performance. We are now also bringing this knowledge to the renewable and net-zero energy sectors.

We pride ourselves on the depth and breadth of specialist engineering and analysis expertise we have built up in the energy sector, for innovative, technology-led, reliability-based, engineered solutions and technology assurance.

Astrimar's engineers are well established in the subsea energy industry having built a strong track record of successful project delivery of complex engineered solutions, typically from first principles. From developing a concept, we can then perform the engineering and detailed engineering analysis, deliver project engineering and management, facilitate or undertake technical assurance, support manufacturing, testing, and commissioning.

At Astrimar we bring advanced engineering practices to the analysis of equipment and systems for operational efficiency, reliability, and integrity. We use our experience and expertise to identify the best solution for each individual problem to maximise value to the client. Solutions are developed with reliability and integrity at the core. Industry best practices (API RP 17Q and 17N) are integral to our business.



OUR TRACK RECORD

Astrimar is proud of our team of **exceptional engineers**, skilled in state-of-the-art **innovative design**, **advanced engineering analysis**, reliability engineering and data analysis.

Astrimar supports clients in the development and implementation of reliability centred solutions using best practice aligned with industry guidance including API RP 17N and Q, the EI Integrity Management Guidelines, DNV RP A203 and ISO 20815. We help our clients integrate system reliability, system design and operations to deliver highly reliable solutions, adding value to their business.

We believe that reliability is an important input to both design and integrity management, to drive down the potential for failure throughout life. It is not just a measured output once design is complete. Therefore taking time to consider potential failure modes, and their impact, as well as making best use of available data, brings real value to our clients' technical decision making.

Our clients, based globally, are operators, system designers, engineering houses, contractors, equipment suppliers and technology developers. Our independent status combined with strong client relationships are vital to us and drive our approach.

Astrimar provides mentoring on innovation and technology qualification and has supported a wide range of start-up technology developers, both directly as Business to Business, and also via grant and accelerator programmes such as Innovate UK's Women in Innovation and NZTC's TechX programmes.

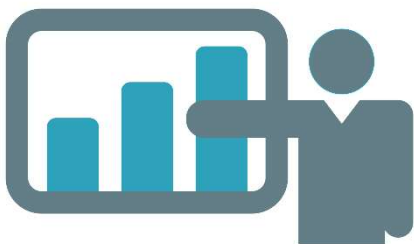

Astrimar also provides a range of training courses on the management of technical risk and reliability, and the application of related techniques and analyses. Our courses range from webinars, lunch and learn sessions, in-person classroom courses and one-to-one coaching.



INDUSTRY SECTORS

Astrimar's **engineered solutions** and **reliability assurance expertise** can add **value** in targeting higher **efficiencies** and protecting client **reputation** irrespective of the industry.

Subsea: Our engineers have been developing and applying subsea reliability best practice for around 25 years with sound experience in engineered solutions, reliability engineering and technology qualification to meet the industry's changing needs for drilling, production, and intervention technologies.

Oil and gas: We provide support from design through operation, life extension and decommissioning to drive production efficiency and long-term integrity, applying reliability engineering to prevent failure and increase efficiency of interventions.

Utilities: We support the prevention or pre-emption of critical failures within energy distribution networks, including preparedness response planning, qualification of novel repair technologies, and analysis of monitoring data to predict and respond to failure causes and mechanisms.

Well Plugging & Abandonment (P&A): Our consultants support the design of challenging well P&A solutions using a risk-based approach to evaluate barrier configurations, including cement and more novel materials requiring qualification evidence. Our track record includes supporting operator well P&A design decisions and ALARP justification to the regulator.

Offshore Renewables: Our specialist engineers support reliability centred design and qualification of marine renewable technologies, data driven condition analysis of offshore wind array cables and optimisation of availability and power generation through cost-effective risk-based maintenance strategies.

Net-zero: Our expertise in design, technology qualification, asset management and innovative risk-based prediction software provides crucial support in all sectors for developing technologies to reduce operational carbon emissions, repurposing existing infrastructure, and developing Carbon Capture, Utilisation and Storage (CCUS) and hydrogen production solutions.

INNOVATIVE SOLUTIONS



Astrimar's engineers provide specialised engineered solutions, design and analysis services through the entire project life cycle.

Our engineers' breadth and depth of expertise and experience enable us to take on the complexity of technical challenges within technology design and project development in order to deliver effective innovative solutions. Astrimar's engineered solutions services are underpinned by design for reliability and technical risk management in order to achieve on-time delivery and through-life reliability performance.

Astrimar's engineers have built a strong track record of successful project delivery in the subsea energy sector. From developing a concept, we also perform the engineering and detailed analysis, deliver project engineering, and support manufacturing, testing and commissioning. For more complete and integrated solutions, Astrimar collaborates closely with other local companies specialised in digital survey, manufacture, and testing.



Astrimar's multi-skilled engineers, are each able to undertake the conceptual modelling, detailed engineering, project management, and offshore support including: Functional, Design, Performance and Reliability Specification; Concept development and evaluation; Front End Engineering Design (FEED); Detailed design and design for manufacture; Project management, from kick-off through to commissioning and in-service support.

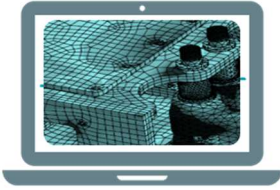

ENGINEERING ANALYSIS

Astrimar's **advanced engineering analysis** capabilities are based on **state-of-the-art tools** and techniques underpinning both our own design solutions and verification of client equipment and designs.

Astrimar's experienced engineers are highly trained in a range of engineering, design, and advanced analysis techniques, applied through conceptual modelling and detailed design, involving both basic and advanced analysis including: Structural (linear and non-linear) Finite Element Analysis (FEA); Computational Fluid Dynamics (CFD), including compressible, incompressible, and multiphase flow; Hydrodynamic analysis; fatigue analysis; design optimisation and numerical analysis. Astrimar's range of reliability analysis tools and techniques are also used to support the engineering design and analysis to ensure all relevant failure modes are identified and addressed.

To provide state-of-the-art engineered solutions, Astrimar invests in state-of-the-art engineering analysis tools. Astrimar's suite of engineering software is reviewed regularly and currently includes: Autodesk Inventor (3D CAD), ANSYS Suite of software, including linear/non-linear FEA, CFD and HPC (multicore high performance computing) and Mathcad (numerical analysis).

Astrimar's engineers ensure compliance with industry standards and recommended practices, including API RP17N and Q using reliability analysis to inform system, assembly and component design, assessing Technology Readiness and developing appropriate Technology Qualification Plans, providing Technology and technical risk assurance, and independent verification.

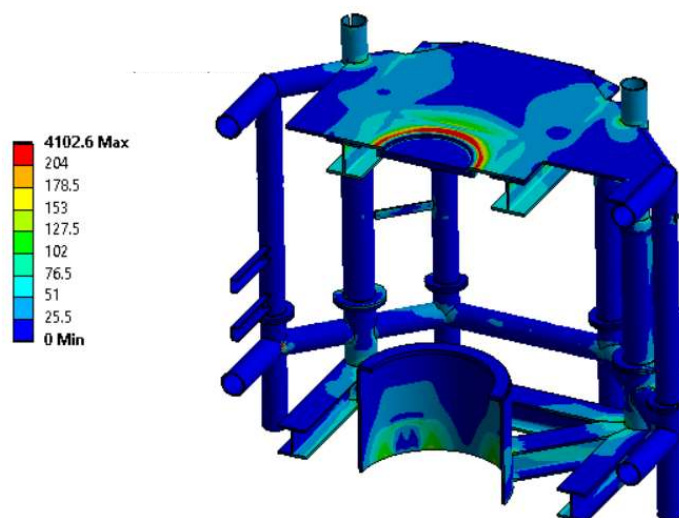



CASE STUDIES

Wellhead Alignment & Torque Transfer System

Our client needed an alternative to a standard wellhead deflector base while achieving the same wellhead alignment and torque transfer capabilities, as part of their well operations.

Astrimar developed a highly innovative, initial concept in the form of a Wellhead Alignment and Torque Transfer System (WATTS), to effectively replace a conventional deflector base. By uniquely decoupling its required functions, we designed independent solutions to address each function. This resulted in a system that provides improved tolerance stack up and alignment, effective torque transfer, reduces manufacturing costs of each system and simplifies installation. Astrimar's scope included conceptual and detailed engineering, engineering analysis, technical risk assurance, including FMECA, manufacture management and test program development.



Re-Entry Hub Removal Tool

As part of a re-development of their ageing subsea assets, our client required the removal of a Re-Entry Hub (REH) from the top of a subsea xmas tree (XT) to allow re-purposing of the well. Due to its age, the REH operability was uncertain.

Astrimar was engaged to develop a bespoke REH removal tool system, to allow the mechanical override of the REH connector in the event that the connector hydraulics were inoperable. The system was also engineered to provide a contingency overpull capacity of 126t in case the REH was seized. The recovery system also features a diver platform and an integrated control panel to allow operation of the removal tool and the REH connector itself, simplifying the dive operation and reducing unnecessary vessel time. A lifting frame was also provided to guide the REH for the initial lift ensuring protection of the vital XT interfaces, ready for the re-purposing of the well.

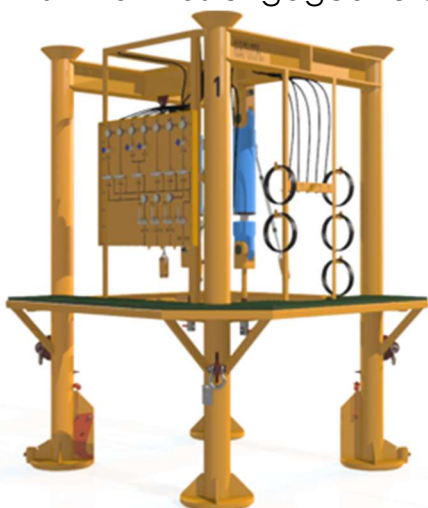



CASE STUDIES

Diver-Installable ROV Panel

Our client required a diver-installable, ROV operable, temporary control panel, which would allow the four hydraulic control lines of the subsea xmas tree (XT) to be operated from a Tree Running Tool (TRT) via a four-port hot-stab connection.



Astrimar designed and delivered a small, lightweight, and robust ROV panel to be installed utilising a bolted connection to the existing XT hang-off beam interface. The design was developed considering ease of diver installation, with low weight, easy access to interfaces and minimum loose parts, to reduce dive vessel time.

The panel incorporated diver-mateable couplings to connect to the XT, a hot-stab receptacle and parking-port, ROV operable needle valves, and a grab handle.

Tubing Hanger Running & Orientation Tool Jigging Skid

Our client had a requirement for jiggling operations to be done onboard a mobile drilling unit. They planned to use a suitable Tubing Hanger Running & Orientation Tool (THROT) Jigging Skid to support and correctly align the Blowout Preventer (BOP) on the central hub, to facilitate effective jiggling operations. Due to the BOP weight and multiple wellhead configuration requirements, no existing equipment was available. Working against a tight timeline Astrimar developed a new skid design able to accommodate different wellhead configurations.

Working with a partner company, Astrimar undertook conceptual design and interface modelling. Astrimar then undertook detailed engineering and analysis of the new skid using partner supplied survey information of the BOP. We then provided project and manufacture management and supported the project through to successful operations in record time.

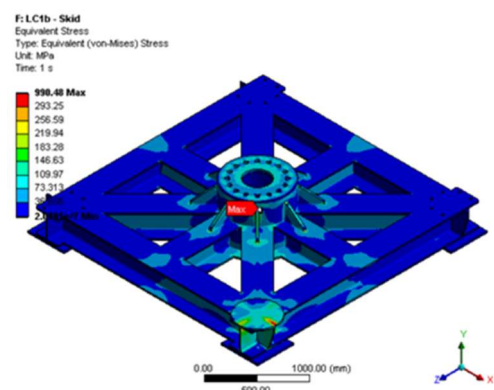

ASSET INTEGRITY MANAGEMENT



Astrimar supports **asset operations** in management of **reliability**, technical risk and integrity during **operations** through to **late life** and **decommissioning**.

Reliability engineering is fundamental to integrity management in operations, building on the earlier analyses and the designed-in reliability.

We work within the constraints of existing designs, performing analytical reviews to highlight component/system failure modes and enhance integrity management and failure preparedness, minimising downtime and maximising production efficiency and integrity.

In Astrimar we use routine inspection, monitoring and test data collected over the life of the asset, in conjunction with our pRIOrity-AIM tool, to identify the onset and progression of degradation mechanisms as equipment ages and the rate at which asset equipment condition is deteriorating. This enables the actual equipment degradation to be accounted for in reliability forecasts and asset risk assessments. By recognising intermediate degradation states, good and bad historical data can be used to maximum value to better interpret current and future condition.

Through an understanding of the risk-based cost benefit of alternative IM strategies and solutions in the light of ongoing degradation and obsolescence risk, Astrimar's engineers are able to design integrity reinstatement and life of field extension solutions, which also support minimum required residual integrity to facilitate decommissioning



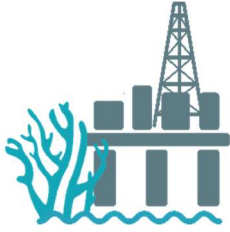

DECOMMISSIONING

Astrimar provides support to asset owners in the selection of **decommissioning** solutions, including **technology** and **risk management** decisions.

For decommissioning, Astrimar utilises best practice methods to evaluate different decommissioning options and technical risks, including the use of technical risk categorization, fault trees and event trees, to support risk-based decision making and option selection.

Developing an understanding of the potential failure modes that may occur through the selected decommissioning process is fundamental to risk management and should be based on reliability engineering and assurance principles.

New technologies for decommissioning are being developed at great pace to meet industry's needs. Performance and life requirements, for example for well plugging technologies, go beyond what can be qualified in standard lab or factory qualification tests. Astrimar uses qualification best practice to support technology and integrity assurance.

Astrimar's STEMflow tool has been developed specifically to support the industry in understanding the technical risks associated with different well P&A designs, including both conventional solutions and those utilising new plug technologies.

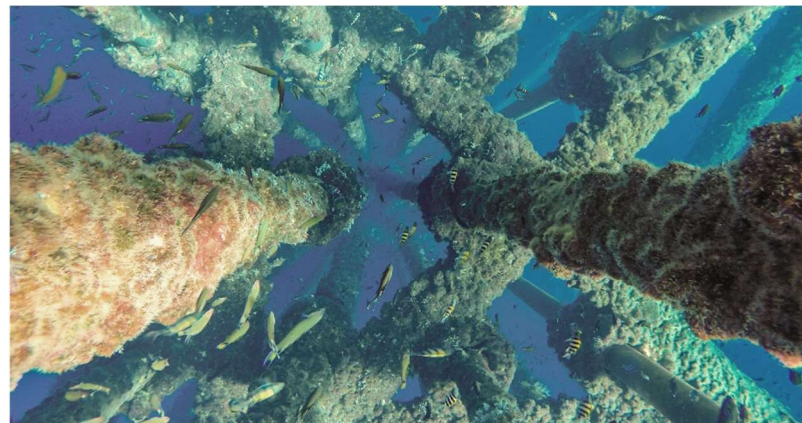

DATA ANALYSIS

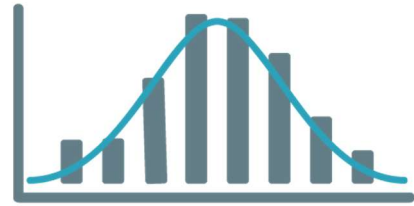

Astrimar analyses **qualification, integrity and failure data** to assess reliability performance and improve estimates of **equipment failure probability**.

Collection and analysis of reliability data is an essential aspect of qualification assurance, integrity management and reliability growth. It also supports continuous learning and improvement both for the operating asset and for future development projects.

Astrimar uses traditional techniques such as Chi-squared and Weibull analysis to estimate equipment failure rate over time and predict future failure probability.

Astrimar also develops bespoke analysis models to make best use of data available, combined with knowledge of degradation processes, to generate the best-informed estimates of reliability over time. Use of data extraction and wrangling techniques using Python, and visualisation of trends and correlations with PowerBI mean that the power of information and knowledge can be unlocked from huge datasets to inform future integrity management decisions.

Some of the most significant data analysis projects undertaken by Astrimar, include analysis of subsea production valve signatures, choke valve parameters, umbilical insulation resistance and offshore wind array cable distributed temperature (DTS) data.

Data analysis is essential to support reliability analyses and management of risk. Since the collection and availability of good reliability performance data is so crucial, Astrimar has also been involved in developing strategic industry databases.

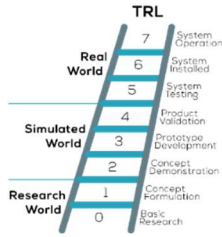

TECHNOLOGY QUALIFICATION

Astrimar assists both technology developers and system operators in the management of risk through **qualification testing** and **analysis**.

When introducing new technology it is essential to understand when it is ready for deployment and the level of risk that deployment entails. Astrimar helps companies to:

- Understand the level of technical risk and uncertainty
- Forecast expected reliability
- Determine/review initial technology readiness level (TRL)
- Identify and plan qualification tests to raise the TRL to the required level
- Understand and collate assurance documentation

We have written client technical practices on technology qualification aligned with DNV RP A203 and API RP 17Q, including the use of both 0 - 7 and 1 – 9 TRL ladders.

In line with DNV RP A203, we use failure modes, effects and criticality analysis (FMECA) to identify potential failure modes as a key input to defining qualification tests and analyses; this is particularly important for prototype, environment and system integration testing.

We use qualification best practice to develop traceable assurance that systems are qualified through a detailed understanding of all service demands, performance requirements, and potential failure mechanisms.

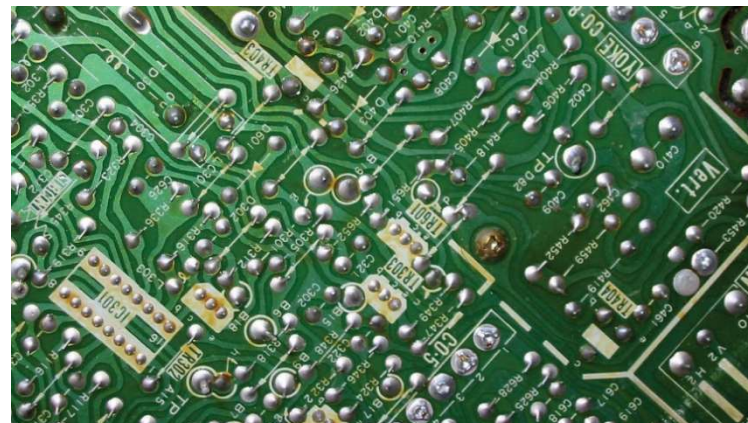

SPECIALIST RELIABILITY TOOLS

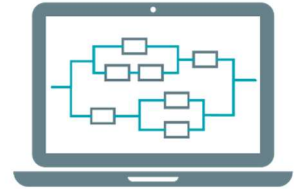

Astrimar develops **advanced data and reliability analysis tools** to efficiently use available data to support reliability, integrity and risk-based decisions.

At Astrimar we strive to integrate sound scientific principles into reliability assessments and forecasts, creating practical tools that can be applied in the analysis of equipment, systems and new technologies. These include application of traditional reliability techniques to more complex algorithms.

Astrimar have created tools for standard Weibull analysis, reliability growth calculations and RBD based RAM analysis as Microsoft Excel add-ins to facilitate routine analysis as part of equipment design, technology qualification and assessment of performance in operation.



RAPAT is our easy-to-use, Excel-based, Innovation Management and Guidance Tool. It's step-by-step framework helps innovators better understand and efficiently navigate, the technical and commercial barriers to product development, qualification, and deployment. From identifying requirements, risks, defining qualification and assurance activities, and collating evidence, RAPAT helps build confidence in new technologies and their readiness for market acceptance.

RAPAT can also be used to support acceptance / procurement authorities reviewing the submitted evidence of the technology's fitness for purpose and certification when required.

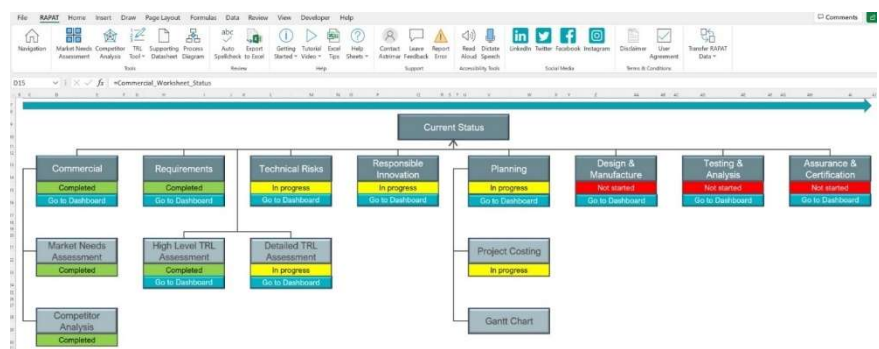



Our pRIOrity-AIM software uses a data-driven, risk-based approach to define inspection and maintenance intervals and is used to support asset integrity management and life extension.

The tool offers a rigorous, yet efficient, statistical method for estimating probability of equipment being in a degraded or failed state. In addition to understanding current equipment condition, it provides a forecast of future equipment condition which is essential if the industry is going to transition to a predictive risk-based approach to asset management. Failure probability is estimated based on actual asset condition and forms an effective basis for determining optimum risk-based intervals for future inspection, testing and monitoring activities.



STEMflow[®]

Astrimar’s STEM-flow, a predictive well integrity tool, provides advanced modelling and data analysis to support well risk assessment and barrier reliability assurance. This novel approach takes account of all potential leak paths including leak paths through a plug, through plug interfaces with the casing and rock formation, and with the casing cement.

The tool is used to support both operators designing well P&A solutions using conventional materials and technology developers qualifying new P&A materials. It can also be used to support operators in developing a justified well integrity management strategy for managing abandoned wells over the long-term and for CCUS applications.

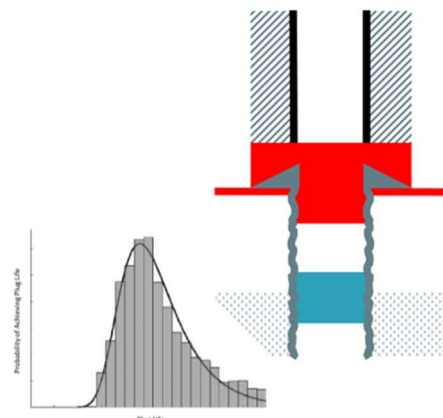

RISK AND RELIABILITY ANALYSIS

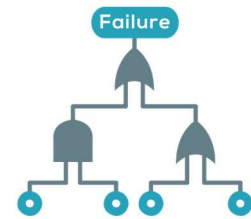

Astrimar uses a range of **reliability**, **availability** and **risk management techniques** to support project design and operations decisions to **maximise uptime**.

Common Cause Failure Analysis (CCFA) - to identify and assess components at risk of (near) simultaneous failure from a common event or environmental condition.

Event Tree Analysis (ETA) - to describe how failure events propagate through a system and determine likely outcomes and consequences.

Failure Mode, Effects and Criticality Analysis (FMEA/FMECA) - to identify system, design or process failure modes for assessing and managing the risk.

Fault Tree Analysis (FTA) - to identify the technical cause of specific unwanted events and predict reliability performance.

Reliability Availability Maintainability (RAM) Analysis - to quantify a system's ability to remain in an operational state.

Risk-Based Decision Making (RBDM) - to support complex project and engineering decisions at each stage, accounting for uncertainty.

Root Cause Failure Analysis (RCFA) - to resolve problems affecting reliability by assessing facts relating to a failure or event at root cause.

Technology Readiness Level (TRL) - to assess current level of readiness of technology for intended application, based on qualification maturity.

Technical Risk Categorisation (TRC) - to assess what is new or changed from previous applications, that introduces uncertainty or risk to reliability.





Engineered Solutions
Technology Qualification
Asset Integrity

Astrimar are experts in the design & analysis of innovative engineered solutions and the provision of reliability, integrity, sustainability & technology assurance for the energy industry

London area

Cranfield Innovation Centre
University Way
Cranfield
MK43 0BT

T +44 (0) 1467 620692
E info@astrimar.com

Aberdeen area

Lethenty Mill Business Centre
Lethenty Mill
Inverurie
AB51 0HQ

T +44 (0) 1467 620692
E info@astrimar.com



www.astrimar.com